

RobUST Kuka KPI Posiflex 72in Robotic Welding System

RobUST pre-engineered welding systems incorporates industry leading technology from Kuka Robotics and Fronius USA into a modular designed robotic cell. The RobUST cell goes beyond previous offerings and is the first system that factors in all challenges with manufacturers today and meets industrial guidelines. The RobUST system offers a complete workflow solution, *addresses floor space, low and high volume fabricator, quick change tooling options, and modular wiring over field bus.*

Standard Cell Features/Advantages

- Kuka (6) Axis Welding Robot
- 1400mm Reach
- Optional 1900mm Reach Robot
- Device Net
- **Modular** Cell Configuration
- (1) Welding Stations 48 x 24
- **Meets ANSI/RIA R15.06-1999 Safety Standards**
- **(1) Robotic Servo Work Turntable**
 - 1000/2000kg Servo Turntable
 - 72in Diameter Turntable
- **MTBF 80,000 Hours on robot and controller**
10,000 & 20,000 hour maintenance intervals
 - *Single point power drop for all electricals*
- **Kuka Robot Controller (KRC)**
 - The KRC robot controller makes programming easier with its Microsoft Windows Interface. It is expandable, can be integrated into networks via a bus, and contains ready-made software packages - all factors which point the way to the industrial automation of the future.

Tooling & Part Size 48L x 24W

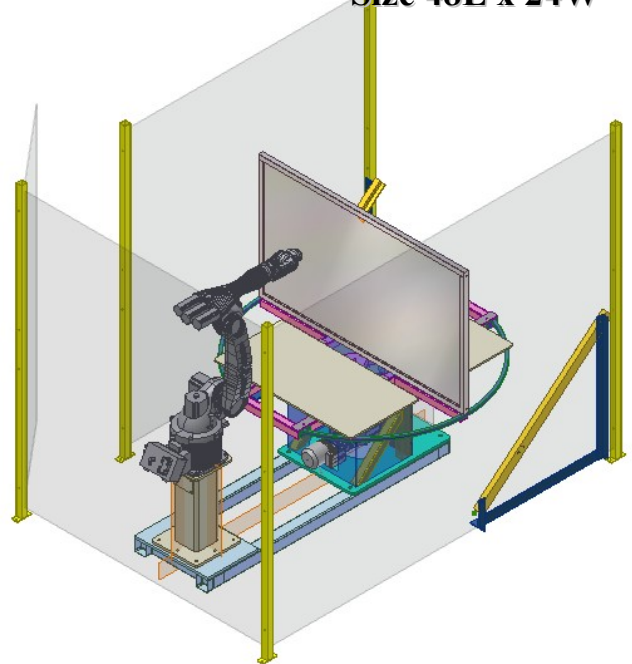

Key Welding Cell Advantages

- **Common Base Configuration**
- **Compact Size & Modular** for easy access to load / unloading
- **Operator load high** optimized for ergonomics
- **Robot Programming** is accessible from the rear of the cell while standing on the floor
- **Quick Change Tooling Option (15 min to change fixture)**
 - *Quick change tooling*
 - *Quick plug and play on fixture electrical and pneumatics*

Fronius Digital Revolution

- **400 Amp CV Inverter Welding Power Supply**
 - Mild Steel Fronius TS 4000 (*Standard*)
 - Stainless steel Fronius TPS 4000 (*Optional*)
 - Aluminum Fronius TPS 4000 (*Optional*)
 - TIG & Plasma (*Custom Configuration*)
- Constant ARC length control
- Most applications on thin gauge material uses .045 welding wire
- Syncro Pulse on Fronius TPS 4000
- **CMT (Cold Metal Transfer MIG Welding)**
 - Cold Metal Transfer Steel/Stainless Steel Aluminum
 - Minimum spatter w/spatter free ignition for penny layer (TIG weld seam appearance)
 - Uses .045 Welding Wire
 - Steel & Aluminum can be welded together
 - Low Thermal Heat Input



RobUST Kuka KPFI Posiflex 72in Robotic Welding System - Configuration & Specifications

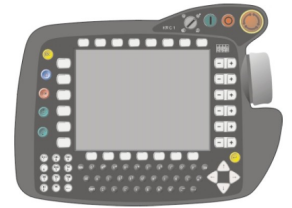
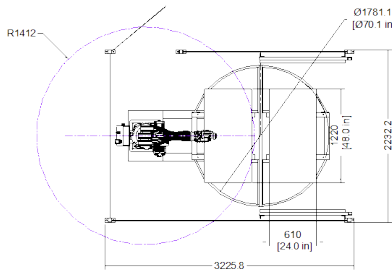

Ergonomically Designed - Features an 8in full-graphics color display

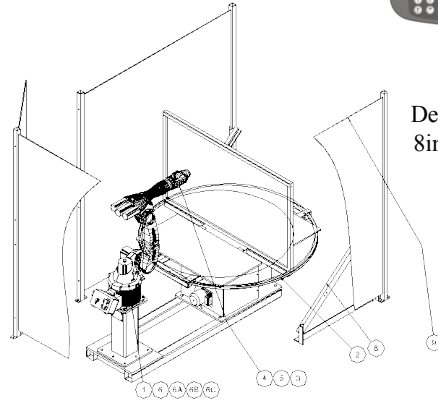
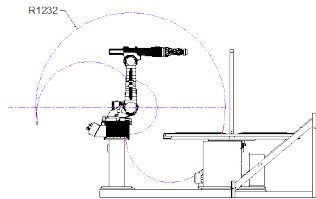
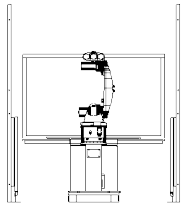

Available Options

- Torch Cleaning Stations
- Fume Extraction & Hoods
- Water Cooled Torch
- Aluminum Welding Packages
- Stainless Steel Welding Packages
- CMT (Cold Metal Transfer MIG)
- Twin Wire Welding Systems
- Touch sensing
- Thru the Arc Tracking
- Field Bus Options
- PLC Packages

Engineering Services

- Welding Analysis
- Cycle time studies
- Reach Studies
- Tooling & Fixturing Design
- Robotic Programming
- PLC & Safety Controller Programming
- Turnkey Solutions
- On Site Engineering and Technician Services

PARTS LIST			
ITEM	QTY	DESCRIPTION	STANDARD/OPTION
1	1	KUKA KR5 ROBOT	STANDARD
2	1	TWO POSITION TABLE 72IN ASSEMBLY	STANDARD
3	1	BINZEL WELD GUN 300 AMP	STANDARD
4	1	FRONIUS WIRE FEEDER	STANDARD
5	1	BULK WELDING WIRE DRUM	OPTION
6	1	ROBOT CONTROLLER	STANDARD
6A	1	ROBOT TEACH PENDANT	STANDARD
6B	1	EXTERNAL SERVO AXIS	STANDARD
6C	1	FIELD BUS CARD D-NET	STANDARD
7	1	TORCH CLEANING STATION	OPTION
8	1	ANGLED LIGHT CURTAIN ASSEMBLY	STANDARD
9	1	FENCE ASSEMBLY	STANDARD
10	1	FRONIUS POWER SUPPLY TS 4000	STANDARD
10A	1	FRONIUS TPS 4000 / CMT HIGHER AMPERAGE, STEEL, STAINLESS STEEL & ALUMINUM AVAILABLE	OPTION

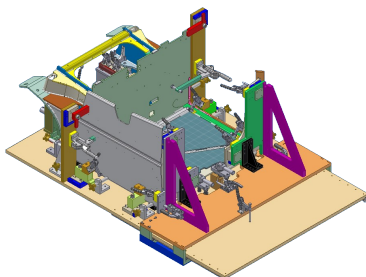

Kuka (6) Axis Robot
1400mm Reach